

SPARE PARTS EXPLODED VIEW INSTANTANEOUS GAS WATER HEATERS

Model
BAYARD STAR 10-13-16 & CM & EQUATION

R8202762-06 - 10/04/2012

EN	FR	IT	ES	DE
-----------	-----------	-----------	-----------	-----------

1	722 921	BAY. STAR 10 CF B/P	01/87	06/90
1	722 931	BAY. STAR 10 CF NAT	01/87	06/90
1	822 921-01	BAY. STAR 10 CF PV b B/P	07/90	06/91
1	822 921-02	BAY. STAR 10 CF PV c B/P	07/91	01/92
1	822 921-03	BAY. STAR 10 CF PV c B/P	02/92	10/95
1	822 931-01	BAY. STAR 10 CF PV b NAT	07/90	06/91
1	822 931-02	BAY. STAR 10 CF PV c NAT	06/91	01/92
1	822 931-03	BAY. STAR 10 CF PV c NAT	02/92	10/95
2	922 921-01	BAY. STAR 10 CF PV d B/P	06/95	10/95
2	922 931-01	BAY. STAR 10 CF PV d NAT	06/95	10/95
2	800 822 921-04	BAY. STAR 10 CF PV (CE) B/P	11/95	...
2	800 822 931-04	BAY. STAR 10 CF PV (CE) NAT	11/95	...
3	412 931-01	CM 10 1F NAT	03/92	10/95
3	422 921-01	CM 10 B/P	03/92	10/95
3	422 931-01	CM 10 NAT	03/92	10/95
4	800 412 931-02	CM 10 1F (CE) NAT	11/95	...
4	800 422 931-02	CM 10 (CE) NAT	11/95	...
5	96 422 931-01	EQUATION 17 NAT	07/92	10/95
5	96 422 921-01	EQUATION 17 B/P	07/92	10/95
6	896 422 931-02	EQUATION 17 (CE) NAT	11/95	...
6	896 422 921-02	EQUATION 17 (CE) B/P	11/95	...
7	722 923-01	BAY. STAR 10 VMC B/P	...	06/90
7	722 933-01	BAY. STAR 10 VMC NAT	...	06/90
7	822 923-01	BAY. STAR 10 VMC b B/P	07/90	02/92
7	822 923-02	BAY. STAR 10 VMC c B/P	03/92	10/95
7	822 933-01	BAY. STAR 10 VMC b NAT	07/90	02/92
7	822 933-02	BAY. STAR 10 VMC c NAT	03/92	10/95
8	800 822 933-03	BAY. STAR 10 VMC (CE) NAT	11/95	...
9	422 933-01	CM 10 VMC NAT	03/92	10/95
10	723 821	BAY. STAR 13 CF B/P	01/87	06/90
10	723 831	BAY. STAR 13 CF NAT	01/87	06/90
10	823 821-01	BAY. STAR 13 CF PV b B/P	07/90	06/91
10	823 821-02	BAY. STAR 13 CF PV c B/P	07/91	01/92
10	823 821-03	BAY. STAR 13 CF PV c B/P	02/92	10/95
10	823 831-01	BAY. STAR 13 CF PV b NAT	07/90	06/91
10	823 831-02	BAY. STAR 13 CF PV c NAT	07/91	01/92
10	823 831-03	BAY. STAR 13 CF PV c NAT	02/92	10/95
11	800 823 831-04	BAY. STAR 13 CF PV (CE) NAT	11/95	...
11	800 823 821-03	BAY. STAR 13 CF PV (CE) B/P	11/95	...
12	896 423 831-01	EQUATION 23 CF PV NAT	10/98	...
12	896 423 821-01	EQUATION 23 CF PV B/P	10/98	...
13	723 823-01	BAY. STAR 13 VMC B/P	...	06/90
13	723 833-01	BAY. STAR 13 VMC NAT	...	06/90
13	823 823-01	BAY. STAR 13 VMC b B/P	07/90	09/91
13	823 823-02	BAY. STAR 13 VMC c B/P	04/92	10/95
13	823 833-01	BAY. STAR 13 VMC b NAT	07/90	09/91
13	823 833-02	BAY. STAR 13 VMC c NAT	04/92	10/95
14	800 823 833-03	BAY. STAR 13 VMC (CE) NAT	11/95	...

Col	Reference	Model type	Begin	End
-----	-----------	------------	-------	-----

15	725 021	BAY. STAR 16 CF B/P	01/87	06/90
15	725 031	BAY. STAR 16 CF NAT	01/87	06/90
15	825 021-01	BAY. STAR 16 CF PV b B/P	07/90	05/91
15	825 021-02	BAY. STAR 16 CF PV c B/P	07/91	02/92
15	825 021-03	BAY. STAR 16 CF PV c B/P	03/92	10/95
15	825 031-01	BAY. STAR 16 CF PV b NAT	07/90	07/91
15	825 031-02	BAY. STAR 16 CF PV c NAT	08/91	02/92
15	825 031-03	BAY. STAR 16 CF PV c NAT	03/92	10/95
16	800 825 021-04	BAY. STAR 16 CF PV (CE) B/P	11/95	...
16	800 825 031-04	BAY. STAR 16 CF PV (CE) NAT	11/95	...
Col	Reference	Model type	Begin	End

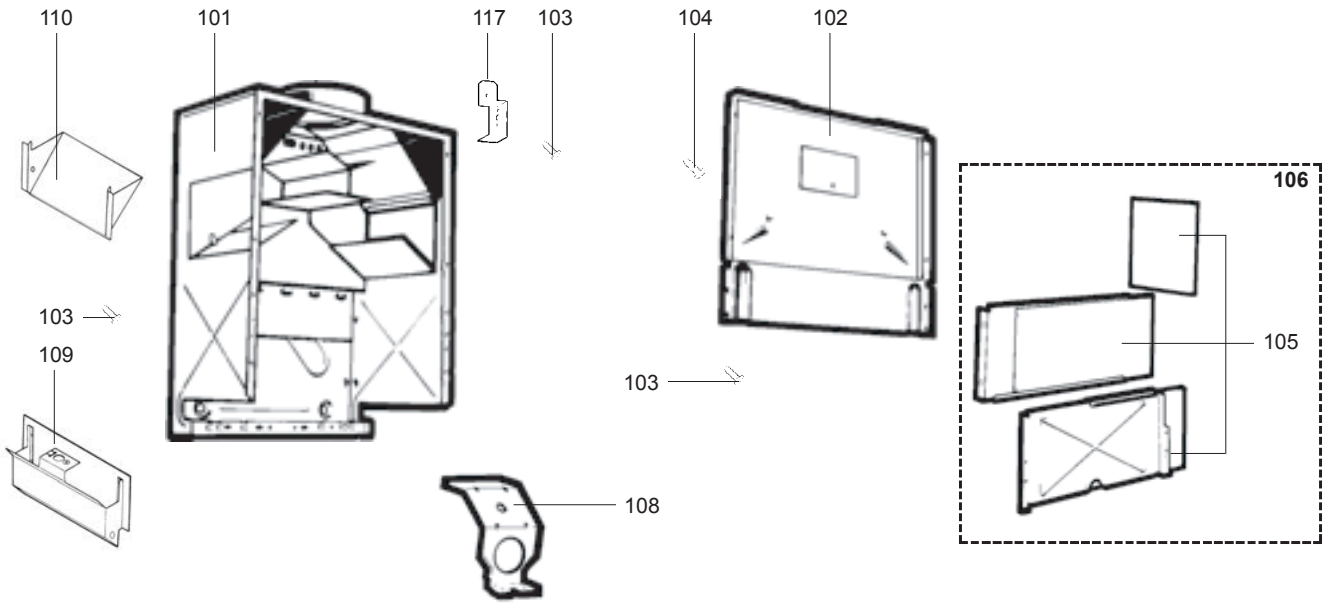

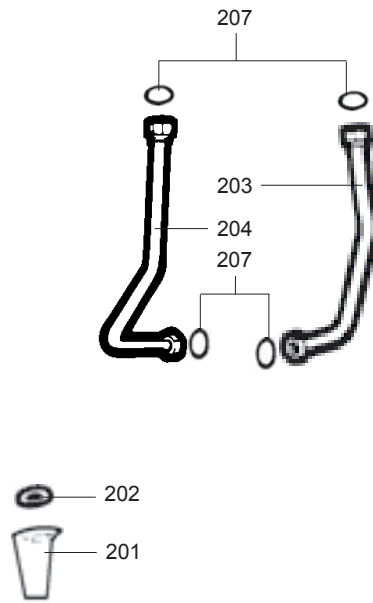
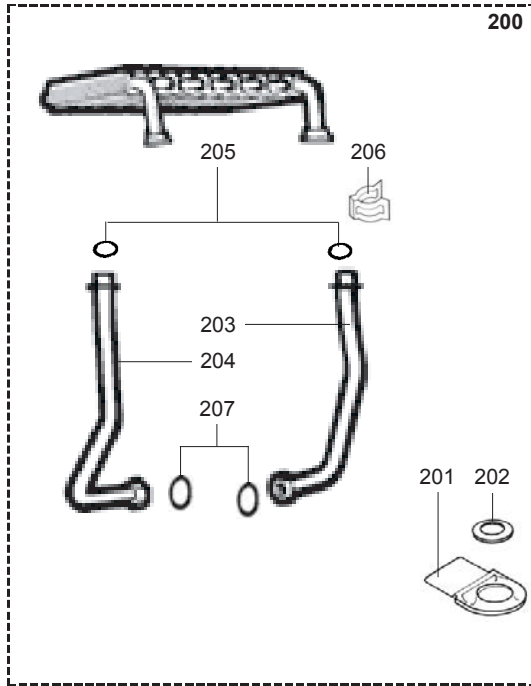

300

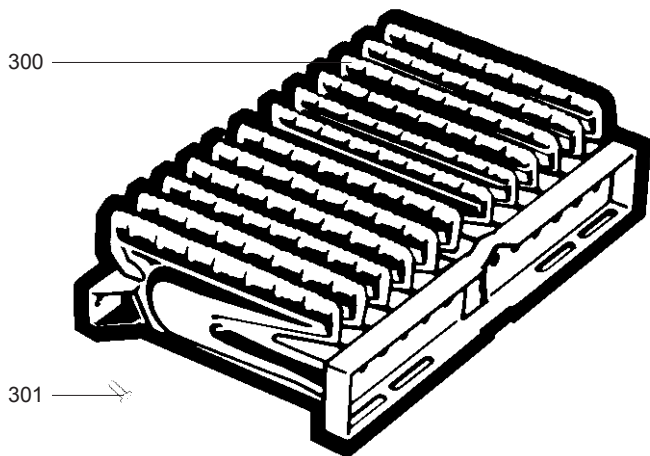

400

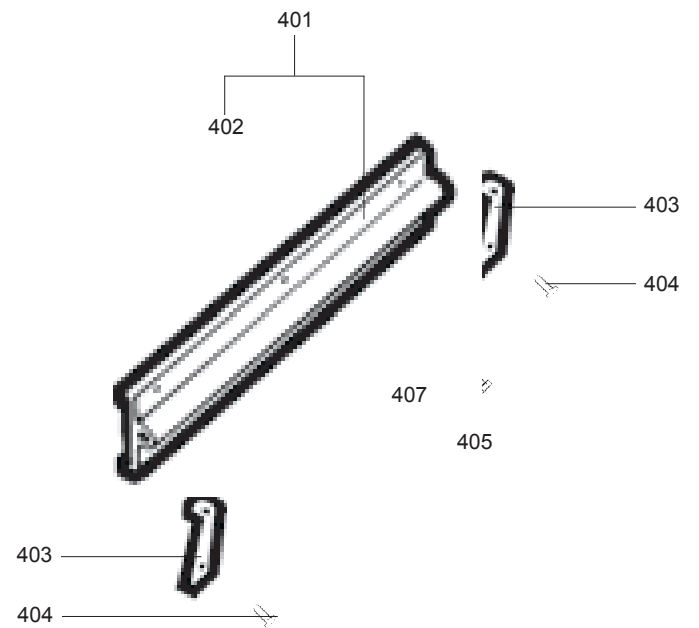

☉⇒	Description	Manf. Pt. N	Type	<div style="display: flex; justify-content: space-between; font-size: small;"> 10 CF - 10 CF b & c 10 CF b & (CE) CM 10 CM 10 (CE) EQUATION 17 EQUATION 17 (CE) 10 VMC b & c 10 VMC (CE) CM 10 VMC 13 CF - 13 CF b & c 13 CF (CE) EQUATION 23 13 VMC b & c 13 VMC (CE) 16 CF - 16 CF b & c 16 CF (CE) </div>																		31
				1	2	3	4	5	6	7	8	9	10	11	12	13	14	15	16	17	18	
0200	HEAT EXCHANGER	60058181-06		•	•	•	•	•	•	•	•	•	•	•	•	•	•	•	•			
	HEAT EXCHANGER	60058679-06										•	•	•	•							
	HEAT EXCHANGER	60061393-06														•	•					
0201	EVAPORATOR	61001675		•	•	•	•	•	•	•	•	•	•	•	•	•	•	•	•			
	DRIP CUP	60070697		•							•											
0202	EVAPORATION GASKET	61001676		•	•	•	•	•	•	•	•	•	•	•	•	•	•	•	•			
	GASKET (/CUP)	60071000		•							•											
0203	COLD WATER TUBE	61001668		•	•	•	•	•	•	•	•	•	•	•	•	•	•	•	•			
	COLD WATER TUBE	61001669									•	•	•	•	•							
	COLD WATER TUBE	61001670														•	•					
	COLD WATER TUBE	60074737		•							•											
0204	HOT WATER TUBE	61000951		•							•											
	HOT WATER TUBE	61001671		•	•	•	•	•	•	•	•	•	•	•	•	•	•	•	•			
	HOT WATER TUBE	61001672									•	•	•	•	•							
	HOT WATER TUBE	61001673														•	•					
	HOT WATER TUBE	60074917-08														•	•					
	HOT WATER TUBE	61000952									•			•								
0205	O-RING D: 12.3-2.4	60024164-47		•	•	•	•	•	•	•	•	•	•	•	•	•	•	•	•			
0206	CLIP	61001674		•	•	•	•	•	•	•	•	•	•	•	•	•	•	•	•			
0207	WASHER D: 18.4-12.2-1.5	60061855-14		•	•	•	•	•	•	•	•	•	•	•	•	•	•	•	•			
0300	BURNER HEAD	60075115									•	•	•									
	BURNER HEAD	60075116														•	•					
0301	TAPPING SCREW CBLX D: 4.2-9.5	61010125		•	•	•	•	•	•	•	•	•	•	•	•	•	•	•	•			
0400	MANIFOLD																					
0401	MANIFOLD LPG KIT	60081083			•																	
	MANIFOLD NAT KIT	60081449			•																	
	MANIFOLD NAT KIT	60081770	NAT														•					
	MANIFOLD NAT KIT	60081323	NAT									•	•		•							
	MANIFOLD LPG KIT	60081327	B/P														•					
	MANIFOLD NAT KIT	60081086	NAT		•		•		•		•											
	MANIFOLD LPG KIT	60081083	B/P	•		•		•		•												
	MANIFOLD LPG KIT	60081084	B/P								•			•								
	MANIFOLD LPG KIT	60081768	B/P		•			•														
	MANIFOLD LPG KIT	60081769	B/P								•	•										
	MANIFOLD NAT KIT	60081140	NAT	•						•												
	MANIFOLD NAT KIT	60081142	NAT								•			•								
	MANIFOLD NAT KIT	60081143	NAT													•						
	MANIFOLD NAT KIT	60081449	NAT	•	•		•		•		•											
	MANIFOLD NAT KIT	60081450	NAT								•			•								
0402	GASKET (/Manifold)	60071226		•	•	•	•	•	•	•	•	•	•	•	•	•	•	•	•			
0403	SUPPORT BRACKET	60061539		•	•	•	•	•	•	•	•	•	•	•	•	•	•	•	•			
0404	TAPPING SCREW CBLX D: 4.2-25	61010128		•	•	•	•	•	•	•	•	•	•	•	•	•	•	•	•			
0405	SCREW HX M 5-12	61010131		•	•	•	•	•	•	•	•	•	•	•	•	•	•	•	•			
0407	WASHER D: 12-5.2-1	60061934-03		•	•	•	•	•	•	•	•	•	•	•	•	•	•	•	•			

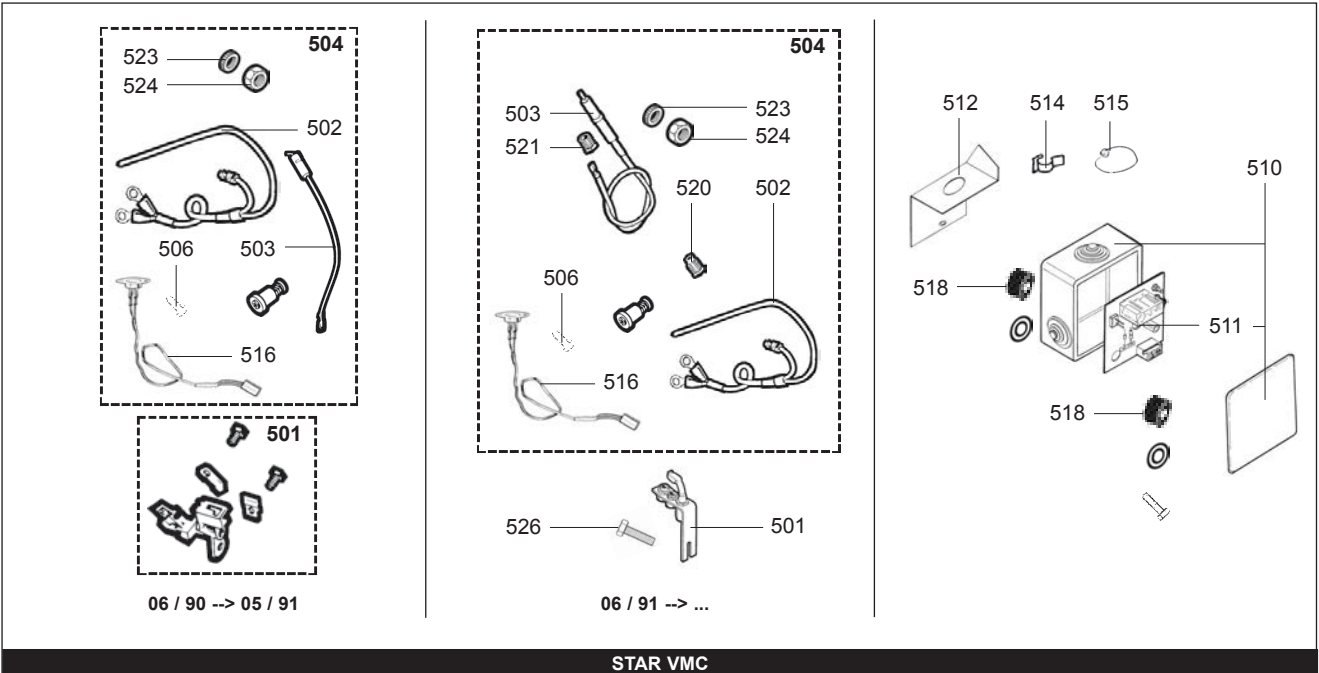
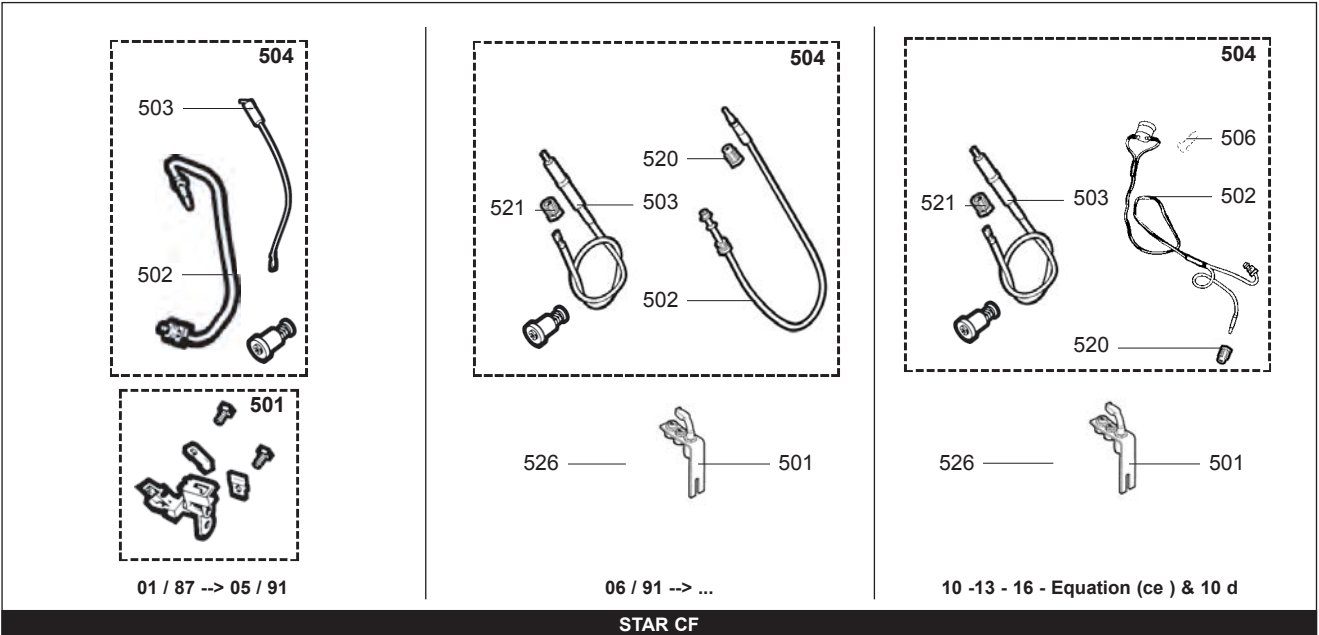

☉⇒	Description	Manf. Pt. N	Type	<div style="display: flex; justify-content: space-between; font-size: small;"> 10 CF - 10 CF b & c 10 CF b & c (CE) CM 10 CM 10 (CE) EQUATION 17 EQUATION 17 (CE) 10 VMC b & c 10 VMC (CE) CM 10 VMC 13 CF - 13 CF b & c 13 CF (CE) EQUATION 23 13 VMC b & c 13 VMC (CE) 16 CF - 16 CF b & c 16 CF (CE) </div>																		<div style="border: 1px solid black; padding: 2px; display: inline-block;">31</div>	
				1	2	3	4	5	6	7	8	9	10	11	12	13	14	15	16	17	18		
0500	IGNITOR																						
0501	IGNITION SUPPORT KIT	60081088		•						•		•		•		•							
	PILOT SUPPORT	61004712		•	•	•	•	•	•	•	•	•	•	•	•	•	•	•	•				
0502	THERMOCOUPLE	60074431		•								•				•							
	THERMOCOUPLE	60079425								•				•									
	THERMOCOUPLE	61004713		•		•		•				•				•							
	THERMO. & O/HEAT THERMO. 105C	61010614			•		•		•			•	•	•		•			•				
0503	ELECTRODE & LEAD ASSY	60081291		•						•		•		•		•							
	ELECTRODE & LEAD ASSY	61009778		•	•	•	•	•	•	•	•	•	•	•	•	•	•	•	•				
0504	FLAME SUPERVISION KIT	60081328		•								•				•							
	FLAME SUPERVISION KIT	60081384								•				•									
	FLAME SUPERVISION KIT	60081446		•		•		•				•				•							
	FLAME SUPERVISION KIT	60081645			•		•		•			•	•	•		•			•				
0506	TAPPING SCREW CBLZ D: 3.5-6.5	60031521-03			•		•		•		•	•	•	•	•	•			•				
0510	INTERFACE BOX & PRINTED CIR.	60081385								•	•	•	•	•	•	•							
0511	PRINTED CIRCUIT BOARD	60079470								•	•	•	•	•	•	•							
0512	SUPPORT BRACKET	61001063								•	•	•	•	•	•	•							
0514	CLIP	61001087								•	•	•	•	•	•	•							
0515	LEAD	60016559-20								•	•	•	•	•	•	•							
0516	OVERHEAT THERMOSTAT 63C ASSY	61004128								•		•		•		•							
	OVERHEAT THERMOSTAT ASSY	61011640								•				•									
0518	CENTRING PIECE	61010241								•	•	•		•	•	•							
0520	CONNECTION M 10x100	61004783		•	•	•	•	•	•	•	•	•	•	•	•	•	•	•	•				
0521	CONNECTION M 10x100	61004711		•	•	•	•	•	•	•	•	•	•	•	•	•	•	•	•				
0523	FAN WASHER D: 4	60028466-03								•	•	•	•	•	•	•							
0524	NUT H M 4-0.70	60022084								•	•	•	•	•	•	•							
0526	SCREW HX M 5-12	61010131		•	•	•	•	•	•	•	•	•	•	•	•	•	•	•	•				

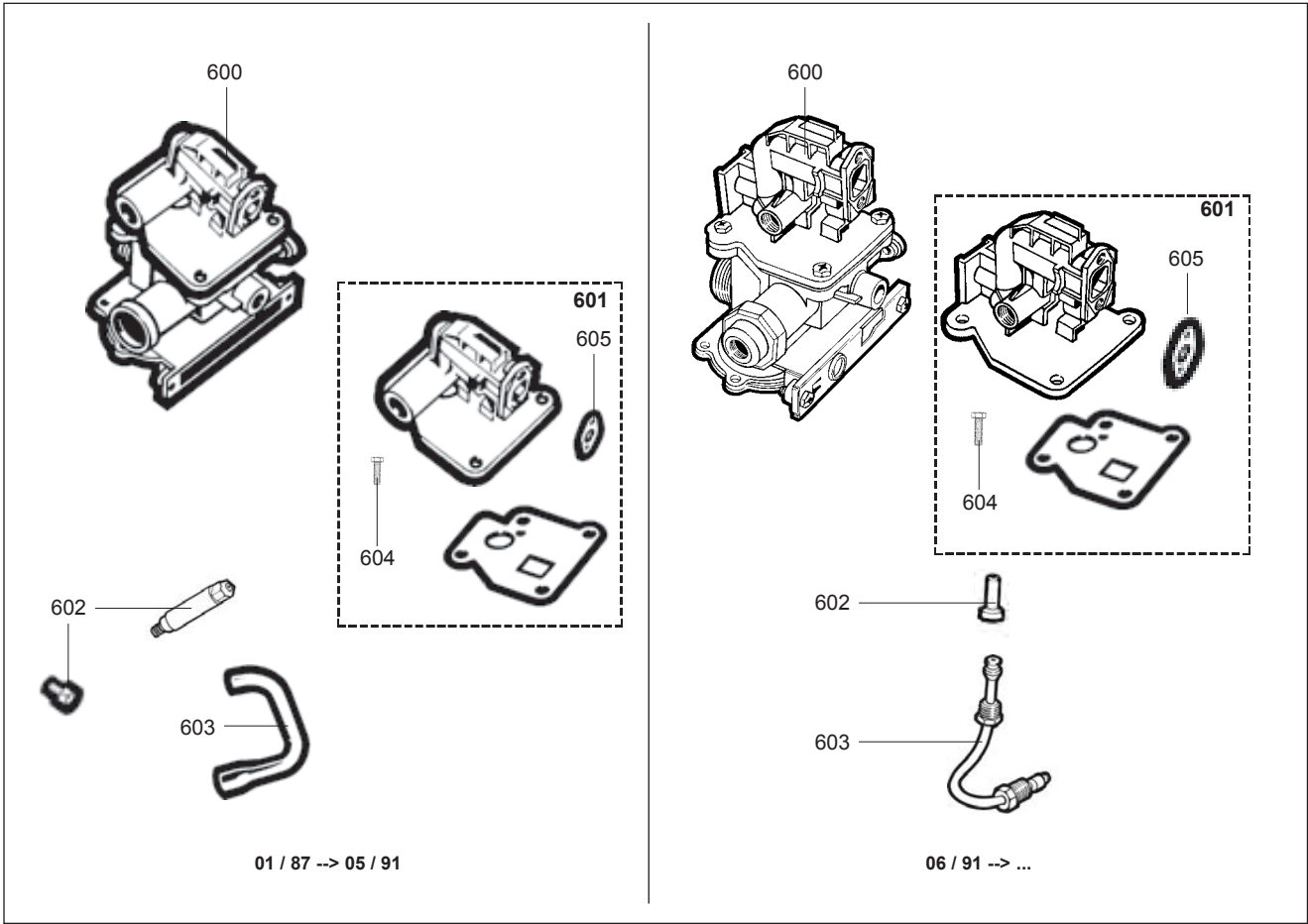

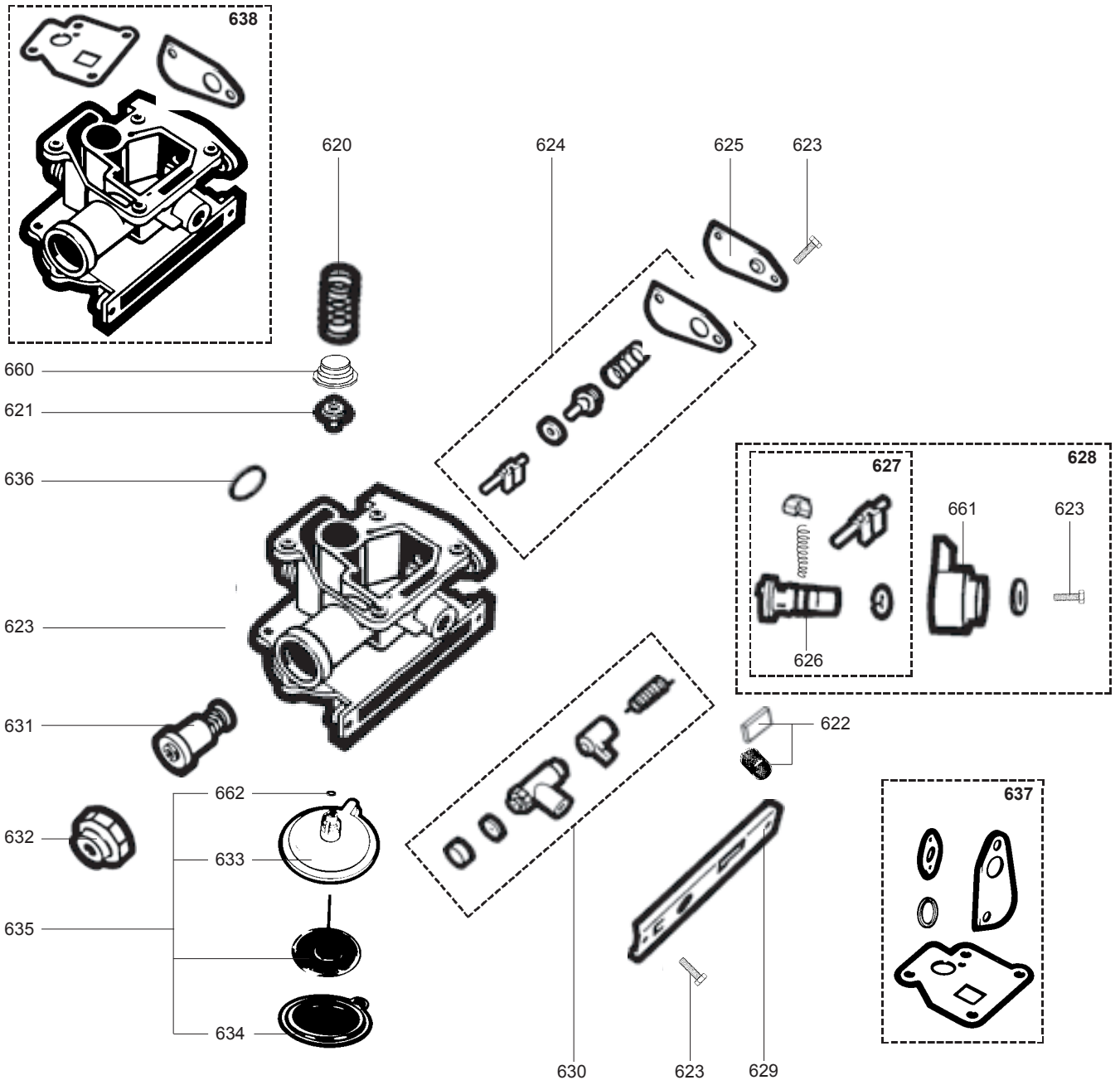

☉⇒	Description	Manf. Pt. N	Type	<div style="display: flex; justify-content: space-between; font-size: small; text-align: center;"> 10 CF - 10 CF b & c 10 CF b & c (CE) CM 10 CM 10 (CE) EQUATION 17 EQUATION 17 (CE) 10 VMC b & c 10 VMC (CE) CM 10 VMC 13 CF - 13 CF b & c 13 CF (CE) EQUATION 23 13 VMC b & c 13 VMC (CE) 16 CF - 16 CF b & c 16 CF (CE) </div>																		<div style="border: 1px solid black; padding: 2px; text-align: center; font-weight: bold;">31</div>	
				1	2	3	4	5	6	7	8	9	10	11	12	13	14	15	16	17	18		
0600	GAS SECTION																						
0620	SPRING	60046722		•	•	•	•	•	•	•	•	•	•	•	•	•	•	•	•				
0621	MAIN GAS VALVE ASSY	60081105-06	B/P																				
	MAIN GAS VALVE ASSY	60081105-03	NAT									•	•	•	•	•	•	•	•				
	MAIN GAS VALVE ASSY	60081105-02	B/P	•	•	•	•	•	•	•													
	MAIN GAS VALVE ASSY	60081105-04	B/P									•	•	•	•								
	MAIN GAS VALVE ASSY	60081105-01	NAT	•	•	•	•	•	•	•	•	•	•	•	•	•	•	•	•				
	MAIN GAS VALVE ASSY	60081105-05	NAT																				
0622	GAS FILTER	60068848		•	•	•	•	•	•	•													
	GAS FILTER	60068848			•															06/95	10/95		
	FILTER	61003811				•		•		•		•	•		•		•						
	FILTER	61003811			•															11/95			
0623	SCREW HX M 5-12	61010131		•	•	•	•	•	•	•	•	•	•	•	•	•	•	•	•				
0624	SECONDARY GAS VALVE LPG	60081092	B/P	•	•	•	•	•	•	•	•	•	•	•	•	•	•	•	•				
	SECONDARY GAS VALVE KIT	60081091	NAT	•	•	•	•	•	•	•	•	•	•	•	•	•	•	•	•				
0625	GAS SECTION COVER	60064588		•	•	•	•	•	•	•	•	•	•	•	•	•	•	•	•				
0626	O-RING D: 6.4-1.9	60021061-11		•	•	•	•	•	•	•	•	•	•	•	•	•	•	•	•				
0627	ECCENTRIC SPINDLE ASSY	60081093		•	•	•	•	•	•	•	•	•	•	•	•	•	•	•	•				
0628	CAM KIT	60081095		•	•	•	•	•	•	•	•	•	•	•	•	•	•	•	•				
0629	PIEZO MECHANISM COVER	60064551		•	•	•	•	•	•	•	•	•	•	•	•	•	•	•	•				
0630	IGNITER ASSY	60081094		•	•	•	•	•	•	•	•	•	•	•	•	•	•	•	•				
0631	THERMOELECTRIC VALVE	60034346		•	•	•	•	•	•	•	•	•	•	•	•	•	•	•	•				
0632	NUT M 27-1	60047707-08		•							•			•						01/87	05/91		
	NUT M 27-1	61004811		•	•	•	•	•	•	•	•	•	•	•	•	•	•	•	•	06/91			
0633	WATER SECTION TOP COVER	60018961		•	•	•	•	•	•	•	•	•	•	•	•	•	•	•	•				
0634	DIAPHRAGM	60025809-30		•	•	•	•	•	•	•	•	•	•	•	•	•	•	•	•				
0635	WATER SECTION REPAIR KIT	60100141-20		•	•	•	•	•	•	•	•	•	•	•	•	•	•	•	•				
0636	SHEET GASKET D: 24-18.2-1.5	60022835-01		•	•	•	•	•	•	•	•	•	•	•	•	•	•	•	•				
0637	GAS SECTION GASKETS KIT	60081096		•	•	•	•	•	•	•	•	•	•	•	•	•	•	•	•				
0638	GAS SECTION ASSY	60081242		•	•	•	•	•	•	•	•	•	•	•	•	•	•	•	•				
0660	SPRING SEAT	61008300		•	•	•	•	•	•	•	•	•	•	•	•	•	•	•	•				
0661	CAM	60064235		•	•	•	•	•	•	•	•	•	•	•	•	•	•	•	•				
0662	O-RING D: 1.9-2.55	60021061-07		•	•	•	•	•	•	•	•	•	•	•	•	•	•	•	•				

700
800

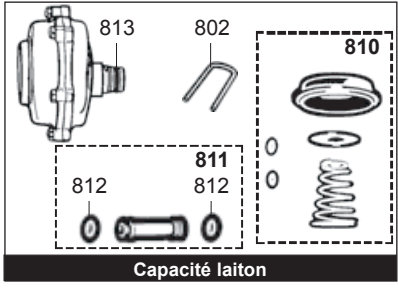
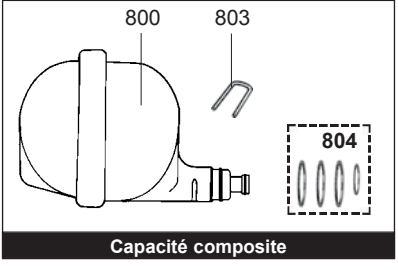
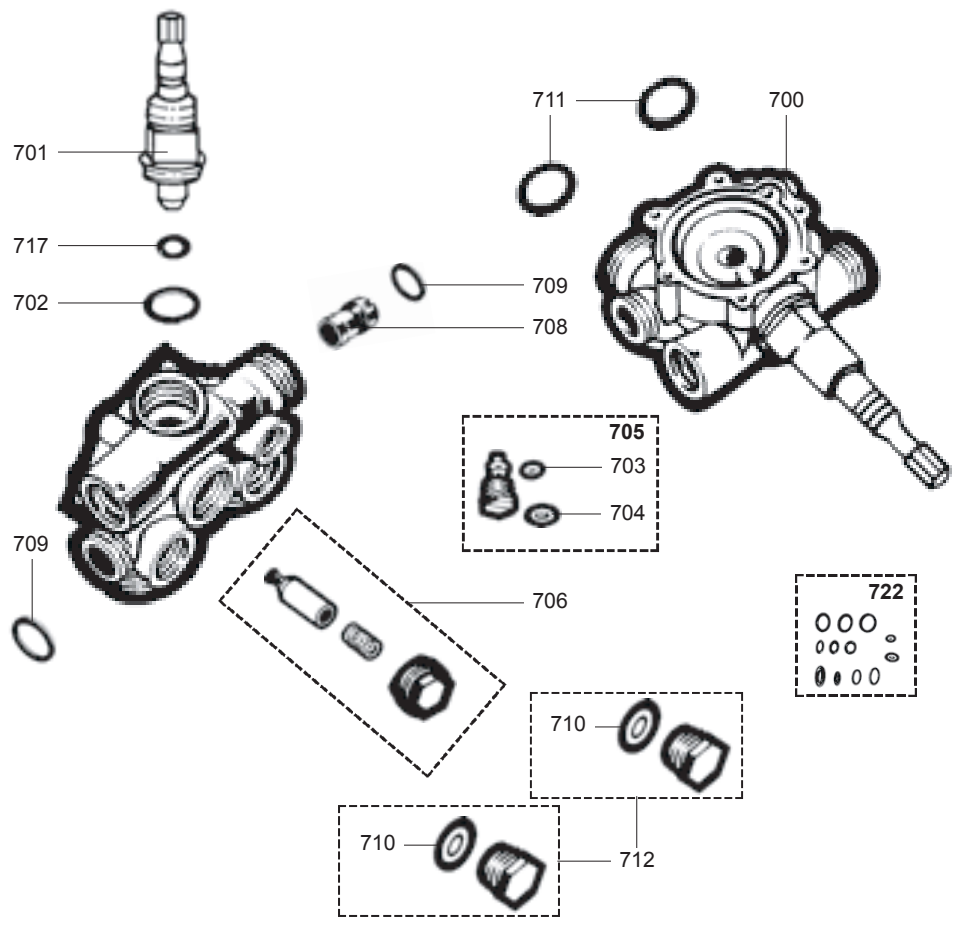

☉⇒	Description	Manf. Pt. N	Type	<div style="display: flex; justify-content: space-between; font-size: small;"> 10 CF - 10 CF b & c 10 CF b & c (CE) CM 10 CM 10 (CE) EQUATION 17 EQUATION 17 (CE) 10 VMC b & c 10 VMC (CE) CM 10 VMC 13 CF - 13 CF b & c 13 CF (CE) EQUATION 23 13 VMC b & c 13 VMC (CE) 16 CF - 16 CF b & c 16 CF (CE) </div>																		31
				1	2	3	4	5	6	7	8	9	10	11	12	13	14	15	16	17	18	
0700	WATER SECTION 2F HP ASSY	60064911		•	•					•	•											
	WATER SECTION 2F HP ASSY	60064912										•	•		•	•						
	WATER SECTION 2F HP ASSY	60064913														•						
	WATER SECTION 2F HP ASSY	61000972		•																		
	WATER SECTION 2F HP ASSY	61000974									•											
	WATER SECTION 2F HP ASSY	61000975														•						
	WATER SECTION 2F HP ASSY	61007338					•	•			•											
	WATER SECTION 2F HP ASSY	61007880											•									
	WATER SECTION 2F HP ASSY	61007951														•	•					
	WATER SECTION 2F HP ASSY	60064911	1F			•	•												05/90			
	WATER SECTION 2F HP ASSY	61007338	2 F			•	•												05/90			
0701	TEMPERATURE SELECTOR ASSY	60064594		•	•	•	•	•	•	•	•											
	TEMPERATURE SELECTOR	60065465														•	•					
	TEMPERATURE SELECTOR ASSY	60066135										•	•	•	•	•	•					
0702	GASKET D: 24.3-21-1.5	60061856-13		•	•	•	•	•	•	•	•	•	•	•	•	•	•	•				
0703	O-RING D: 4.9-1.9	60024164-09		•	•	•	•	•	•	•	•	•	•	•	•	•	•	•				
0704	O-RING D: 8.9-1.9	60024164-13		•	•	•	•	•	•	•	•	•	•	•	•	•	•	•				
0705	SLOW IGNITION DEVICE ASSY	60081110		•	•	•	•	•	•	•	•	•	•	•	•	•	•	•				
0706	WATER GOVERNOR KIT	60081097		•	•	•	•	•	•	•	•	•	•	•	•	•	•	•				
0708	VENTURI D: 4.5	60066870-08		•	•	•	•	•	•	•	•											
	VENTURI D: 5.5	60066871-08										•	•	•	•							
	VENTURI D: 6.5	60066873-08														•	•					
0709	WASHER D: 18.4-12.2-1.5	60061855-14		•	•	•	•	•	•	•	•	•	•	•	•	•	•	•				
0710	SHEET GASKET D: 17.9-11.7-1.5	60061854-02		•	•	•	•			•	•			•	•	•	•	•				
0711	SHEET GASKET D: 24-16.2-1.5	60061855-02														•	•					
	SHEET GASKET D: 23.8-14.4-1.5	60061855-18		•	•	•	•	•	•	•	•	•	•	•	•	•	•	•				
0712	PLUG	60077703		•	•	•	•			•	•			•	•	•	•	•				
0717	O-RING D: 5.7-1.9	60024164-10		•	•	•	•	•	•	•	•	•	•	•	•	•	•	•				
0722	WASHER SET	60081118		•	•	•	•	•	•	•	•	•	•	•	•	•	•	•				
0800	COMPOSIT SCALE REDUCER 13-16L	61000880										•	•	•	•	•	•					
	COMPOSIT SCALE REDUCER 10L	61003859		•	•	•	•	•	•	•	•											
0802	CLIP	60074418		•								•				•						
0803	CLIP	61000729		•	•	•	•	•	•	•	•	•	•	•	•	•	•	•				
0804	GASKETS KIT	60081452		•	•	•	•	•	•	•	•	•	•	•	•	•	•	•				
0810	SCALE REDUCER KIT	60081240		•								•				•						
0811	LINKING TUBE ASSY	60081138		•								•				•						
0812	O-RING D: 7.2-1.9	60024164-12		•								•				•						
0813	O-RING D: 13.6-2.7	60024164-18		•								•				•						

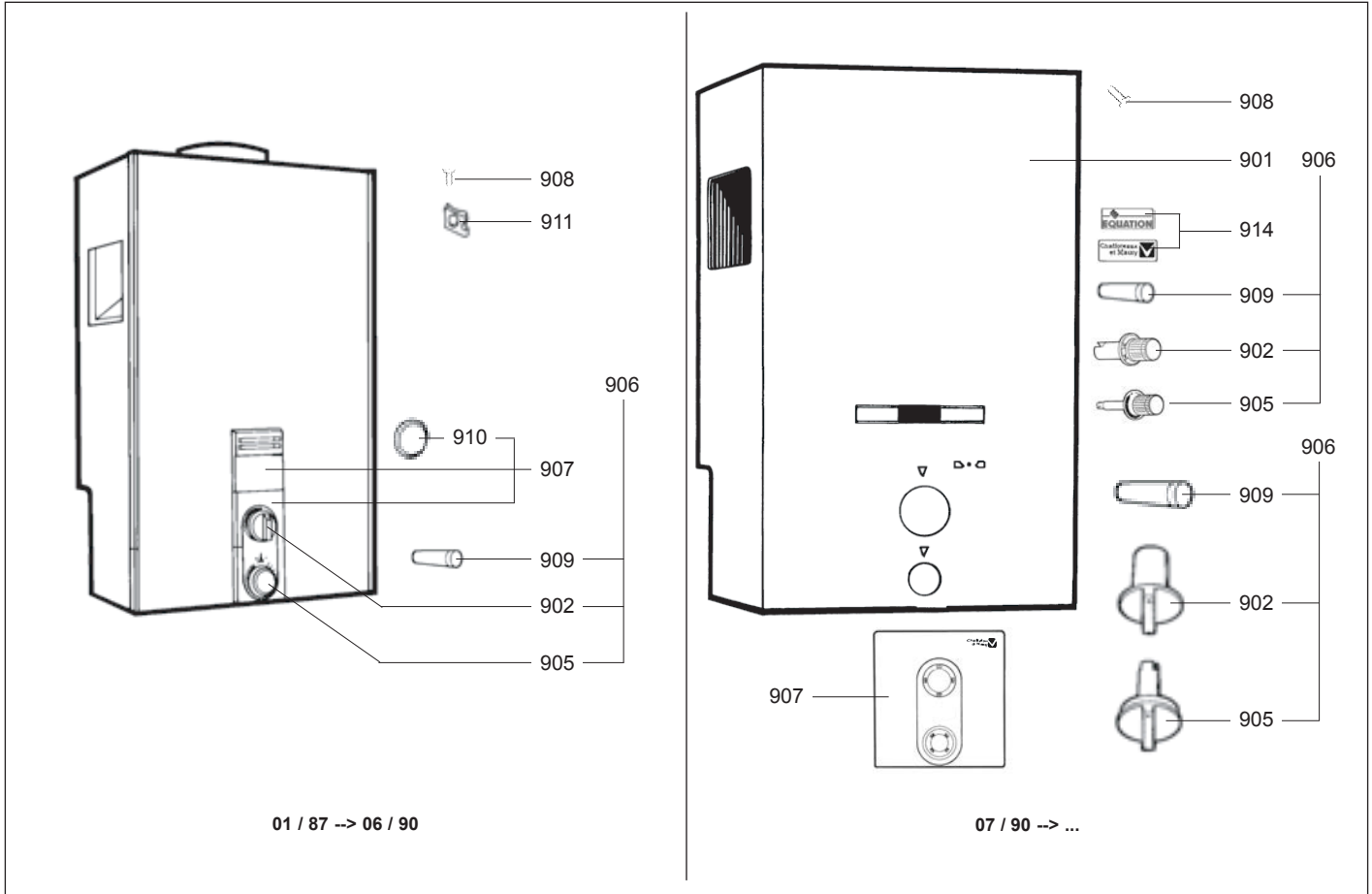

☺⇒	Description	Manf. Pt. N	Type	<div style="display: flex; justify-content: space-between; font-size: small;"> 10 CF - 10 CF b & c 10 CF b & (CE) CM 10 CM 10 (CE) EQUATION 17 EQUATION 17 (CE) 10 VMC b & c 10 VMC (CE) CM 10 VMC 13 CF - 13 CF b & c 13 CF (CE) EQUATION 23 13 VMC b & c 16 VMC (CE) 16 CF - 16 CF b & c 16 CF (CE) </div>																		31
				1	2	3	4	5	6	7	8	9	10	11	12	13	14	15	16	17	18	
0900	FRONT CASE																					
0901	FRONT CAS PAINTED	61001490		•	•	•	•	•	•	•												
	FRONT CASE PAINTED	61001492													•	•						
0902	GAS CONTROL KNOB	61001496		•	•				•	•	•	•	•	•	•	•			07/90			
	GAS CONTROL KNOB	61007184						•	•			•										
	GAS CONTROL KNOB	61007384				•	•			•												
	GAS CONTROL KNOB	60074842		•						•					•				01/87 06/90			
0905	TEMPERATURE SELECTOR KNOB	60074520		•						•					•				01/87 06/90			
	TEMPERATURE SELECTOR KNOB	61001497		•	•				•	•	•	•	•	•	•	•			07/90			
	SELECTOR KNOB	61007185						•	•			•										
	TEMPERATURE SELECTOR KNOB	61007385				•	•			•												
0906	KNOBS SET	61001782		•	•				•	•	•	•	•	•	•	•			07/90			
	KNOBS SET	61007402				•	•			•												
	KNOBS SET	61007402-04						•	•			•										
	KNOBS SET	60079544		•						•					•				01/87 06/90			
0907	PRINTED FACIA 2F	61018771	PN	•	•				•	•	•	•	•	•	•	•						
0908	TAPPING SCREW CBLX D: 4.2-9.5	61010125		•	•	•	•	•	•	•	•	•	•	•	•	•	•					
0909	ADJUSTING OLIVE	60070493		•	•				•	•	•	•	•	•	•	•						
	ADJUSTING OLIVE	61007404				•	•			•												
0910	FACIA PLUG	60076249		•						•					•				01/87 05/90			
0911	SPIRE CLIP	60072411		•						•					•							
0914	LOGO SUPPORT CM 10	61007390				•	•			•												
0918	CASING REPLACEMENT KIT	60081731		•																		

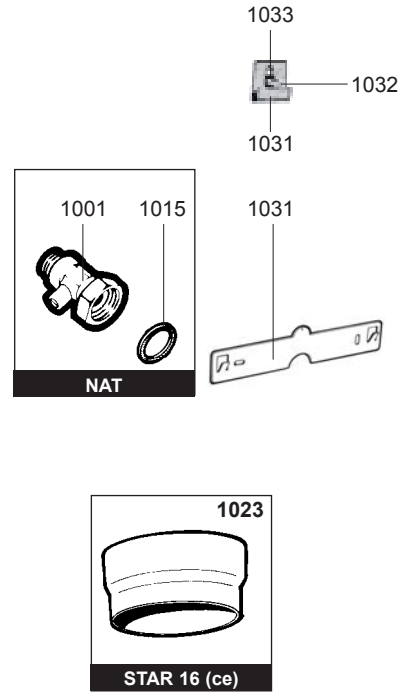
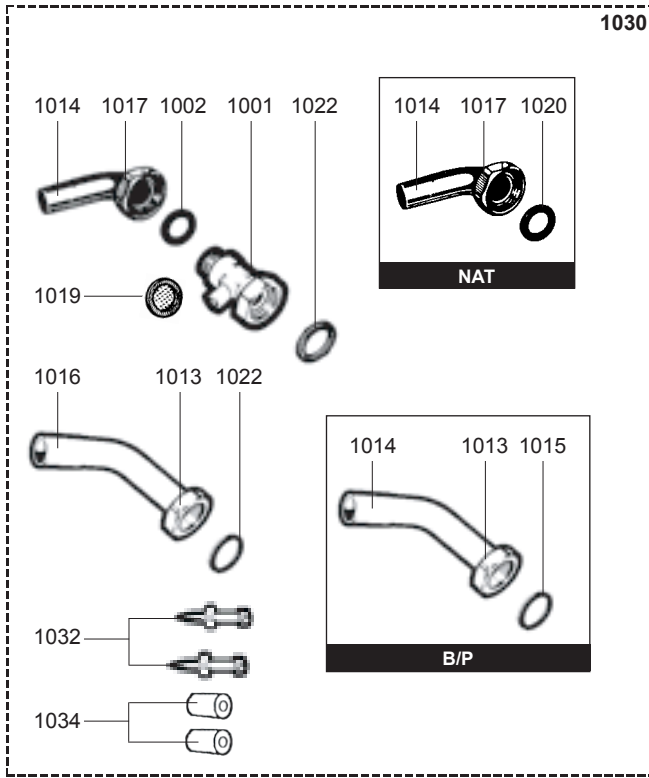

☉⇒	Description	Manf. Pt. N	Type	<div style="display: flex; justify-content: space-between; font-size: small;"> 10 CF - 10 CF b & c 10 CF b & (CE) CM 10 CM 10 (CE) EQUATION 17 EQUATION 17 (CE) 10 VMC b & c 10 VMC (CE) CM 10 VMC 13 CF - 13 CF b & c 13 CF (CE) EQUATION 23 13 VMC b & c 13 VMC (CE) 16 CF - 16 CF b & c 16 CF (CE) </div>																		31
				1	2	3	4	5	6	7	8	9	10	11	12	13	14	15	16	17	18	
1000	JIG PLATE & PIPE FITTING																					
1001	ISOLATING COCK	60074427		•	•	•	•	•	•	•	•	•	•	•	•							
	ISOLATING COCK	60074801														•	•					
1002	WASHER D: 18.4-12.2-1.5	60061855-14		•	•	•	•	•	•	•	•	•	•	•	•	•	•					
1013	NUT 3/4"	60049772-18		•	•	•	•	•	•	•	•	•	•	•	•	•	•					
1014	CONNECTING PIPE	60074765		•	•	•	•	•	•	•	•	•	•	•	•	•	•					
	CONNECTING PIPE	60074767-08																				
	CONNECTING PIPE	60078729-08	B/P	•	•	•	•	•	•		•	•	•	•		•	•					
1015	SHEET GASKET D: 24-18.2-1.5	60022835-01		•	•	•	•	•	•	•	•	•	•	•	•	•	•					
1016	CONNECTING PIPE	60074766		•	•	•	•	•	•	•	•	•	•	•	•	•	•					
1017	NUT 1/2" THICK: 10	60020747-38		•	•	•	•	•	•	•	•	•	•	•	•	•	•					
1019	WATER FILTER	61007727			•	•		•		•	•	•	•	•	•	•	•					
1020	SHEET GASKET D: 18.4-12.2-1.5	60022835-14		•	•	•	•	•	•	•	•	•	•	•	•	•	•					
1022	SHEET GASKET D: 24-16.2-1.5	60061855-02																				
	SHEET GASKET D: 23.8-14.4-1.5	60061855-18		•	•	•	•	•	•	•	•	•	•	•	•	•	•					
1023	FLUE SPIGOT	61012134																	•			
1030	CONNECTION KIT	61011256	B/P						•			•	•									
	CONNECTION KIT	61011256	B/P		•														11/95			
	CONNECTION KIT	60075240	NAT														•					
	CONNECTION KIT	60075187			•														06/95 10/95			
	CONNECTION KIT	60075187	B/P	•	•	•	•	•		•		•										
	CONNECTION KIT	60075186			•														06/95 10/95			
	CONNECTION KIT	60075186	NAT	•	•	•	•	•	•	•		•		•								
1031	FIXING BRACKET	60054606		•	•	•	•	•	•	•	•	•	•	•	•	•	•		01/87 01/92			
	HOOKING BRACKET	61007192		•	•	•	•	•	•	•	•	•	•	•	•	•	•		02/92			
1032	WOOD SCREW	60025617-03		•	•	•	•	•	•	•	•	•	•	•	•	•	•					
1033	WASHER D: 25-6.5-1.5	60035378-03		•					•		•		•		•							
1034	WATER TIGHTNESS SLEEVE	61007223		•	•	•	•	•	•	•	•	•	•	•	•	•	•					

1350

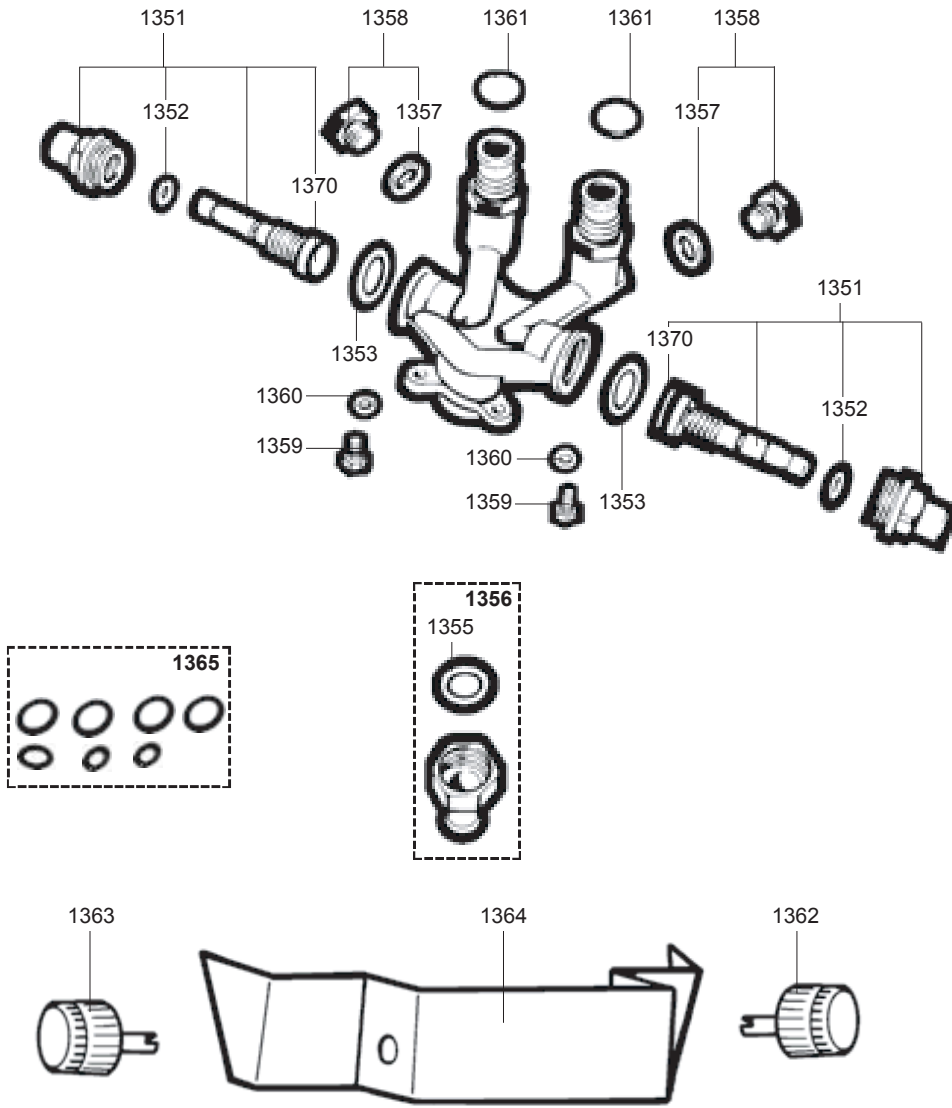

5000

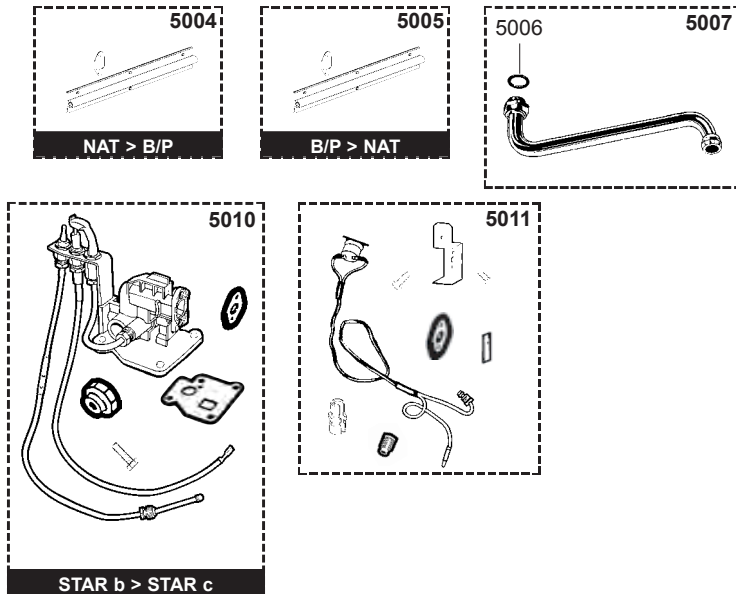

☉⇒	Description	Manf. Pt. N	Type	<div style="display: flex; justify-content: space-between; font-size: small;"> 10 CF - 10 CF b & c 10 CF b & c (CE) CM 10 CM 10 (CE) EQUATION 17 EQUATION 17 (CE) 10 VMC b & c 10 VMC (CE) CM 10 VMC 13 CF - 13 CF b & c 13 CF (CE) EQUATION 23 13 VMC b & c 13 VMC (CE) 16 CF - 16 CF b & c 16 CF (CE) </div>																		31		
				1	2	3	4	5	6	7	8	9	10	11	12	13	14	15	16	17	18			
1350	MIXING BATTERY	61001856		•	•					•	•	•	•	•										
1351	TAP HEAD ASSY	60060863										•	•	•	•				01/87 05/90					
	TAP HEAD ASSY	61001862		•	•					•	•	•	•	•					06/90					
1352	O-RING D: 5.7-1.9	60024164-10		•	•					•	•	•	•	•										
1353	GASKET D: 24.3-21-1.5	60061856-13		•	•					•	•	•	•	•										
1355	SHEET GASKET D: 18.2-15-1.5	60061855-15		•	•					•	•	•	•	•										
1356	JET OUTLET KIT	60081102		•	•					•	•	•	•	•										
1357	WASHER D: 18.4-12.2-1.5	60061855-14		•	•					•	•	•	•	•										
1358	PLUG KIT	60081103		•	•					•	•	•	•	•										
1359	SCREW HX M 5-12	61010131		•	•					•	•	•	•	•										
1360	SPRING WASHER D: 5	60037227-03		•	•					•	•	•	•	•										
1361	SHEET GASKET D: 17.9-11.7-1.5	60061854-02		•	•					•	•	•	•	•										
1362	CONTROL KNOB	60074522		•	•						•								01/87 05/90					
	COLD WATER KNOB	61001499		•	•					•	•	•	•	•					06/90					
1363	HOT WATER KNOB	61001498		•	•					•	•	•	•	•					06/90					
1364	PLATE - IMMEDIATE WATER INTAKE	60075710		•															01/87 05/90					
	IMMEDIATE WATER INTAKE CASING	61001493		•	•					•	•	•	•	•					06/90					
1365	GASKET KIT	60081104		•	•					•	•	•	•	•										
1370	WATER VALVE D: 15.8-5	60009433		•	•					•	•	•	•	•										
5000	ACCESSORIES																							
5004	CONVERSION KIT NAT > LPG	60321608-91		•						•									01/87 05/91					
	CONVERSION KIT NAT > LPG	60321609-91									•		•						01/87 05/91					
	CONVERSION KIT NAT > LPG	61004882		•	•	•		•		•									06/91					
	CONVERSION KIT NAT > LPG	61004882			•														06/95 10/95					
	CONVERSION KIT NAT > LPG	61004884									•		•						06/91					
	CONVERSION KIT NAT > LPG	61007405-54			•			•											11/95					
	CONVERSION KIT NAT > LPG	61007405-69									•	•												
	CONVERSION KIT NAT > LPG	60321610-91														•			01/87 05/91					
	CONVERSION KIT NAT > LPG	61004886														•			06/91					
	CONVERSION KIT NAT > LPG	61007405-79															•							
5005	CONVERSION KIT LPG > NAT	60321608-81		•						•									01/87 05/91					
	CONVERSION KIT LPG > NAT	60321609-81									•		•						01/87 05/91					
	CONVERSION KIT LPG > NAT	61004883		•	•	•		•		•									06/91 10/95					
	CONVERSION KIT LPG > NAT	61004885									•		•						06/91					
	CONVERSION KIT LPG > NAT	61007405-70									•	•												
	CONVERSION KIT LPG > NAT	61007405-80															•							
	CONVERSION KIT LPG > NAT	60321610-81														•			01/87 05/91					
	CONVERSION KIT LPG > NAT	61004887														•			06/91					
	CONVERSION KIT LPG > NAT	61007405-55			•	•		•											11/95					
5006	SHEET GASKET D: 18.2-15-1.5	60061855-15		•	•					•	•	•	•	•										
5007	SWIVEL SPOUT 0.15 M D:15x21	60081749		•	•					•	•	•	•	•										
	SWIVEL SPOUT 0.25 M D:15x21	60081750		•	•					•	•	•	•	•										
5010	BASE & PILOT NAT KIT	61004723	NAT	•							•					•			06/90 05/91					
5011	OVERFLOWING SAFETY KIT	61012187			•	•		•				•	•				•		11/95					

LIST OF THE ABBREVIATIONS

HW	: Hot water.
CW	: Cold water.
C	: Ceramic resistance (normal heating).
Ca	: Ceramic resistance (accelerated heating)
TP	: Immersion heater.
1F	: With fittings.
2F	: Without fittings.
3F	: With fittings and another outlet connection.
AMI	: With mixing valve.
SMI	: Without mixing valve.
PUISS	: Power of th appliance.
PN	: Appliance with normal pression.
LP	: Appliance with low pression.
PV	: Appliance with variable power.
PF	: Appliance with fixed power.

IDENTIFICATION PLATE

SERIAL NUMBER

10 Characters :	04 05 125 011	
		Sequential number
		Manufacturing day
		Year of manufacture
11 Characters :	1 95 065004 - 31	
Month of manufacture :		Technical number of the appliance
from 1 to 9 → Jan. to Sep.,		Sequential number
O → Oct., N → Nov.,		Year of manufacture
D → Dec.		
19 Characters :	08 05 0013199 900640031	
Year of manufacture		Product reference
Month of manufacture		Sequential number
20 Characters :	3675007 XX 2 07 070 00315	
Product reference		Sequential number
Millenium of manufacture		Manufacturing day
		Year of manufacture
21 Characters :	3675007 XX 07 070 0000315	
Product reference		Sequential number
Year of manufacture		Manufacturing day

The indications mentioned on the prices, commercial or technical literature and the scheme are written for your guidance and are available at a given time. The CONSTRUCTOR retains the power to modify the presentation, the form, the size, the conception or the material of the products.